

# Revolutionizing Industrial Operations: The Impact of 6206RS Bearings

## 1 Introduction

In the realm of industrial operations, the seamless functioning of machinery and equipment forms the cornerstone of efficiency and productivity. Central to this efficiency are bearings, which serve as the silent heroes facilitating smooth motion and reducing friction in various mechanical systems. Among these, the 6206RS bearing stands out as a symbol of innovation and reliability, revolutionizing the landscape of industrial operations.

The [6206RS bearing](#), a type of sealed ball bearing renowned for its durability and performance, plays a pivotal role in optimizing machinery performance across diverse industrial sectors. From automotive assembly lines to heavy manufacturing plants, the impact of 6206RS bearings reverberates through every cog and gear, ensuring precision, reliability, and operational excellence.

Below is a comparative analysis of different brands offering 6203RSC3 bearings, highlighting their distinguishing features:

Brand	Features	Advantages	Disadvantages
SKF	- High-quality, widely used in industrial sectors	- High wear resistance	- Relatively higher price
NSK	- Globally leading bearing manufacturer	- High reliability	- May not offer as high stability in some specialized applications
FAG	- German-made with a renowned reputation	- Excellent corrosion resistance	- May not have as wide availability in some markets
NTN	- Japanese manufacturing with reliable quality	- Good value for money	- May not have as high brand recognition in certain regions
Timken	- Made in USA with rich experience	- Technologically advanced	- Relatively smaller market share in some regions

Each of these brands has its own strengths and characteristics when it comes to 6206RS type bearings. The choice of the most suitable brand depends on specific application requirements, available budget, and the need for reliability and performance.

As we delve deeper into the significance of 6206RS bearings in industrial operations, it becomes evident that

these components represent more than mere mechanical parts—they embody a commitment to efficiency, sustainability, and technological advancement. Through this exploration, we aim to shed light on the transformative impact of 6206RS bearings and their contribution to shaping the future of industrial manufacturing.

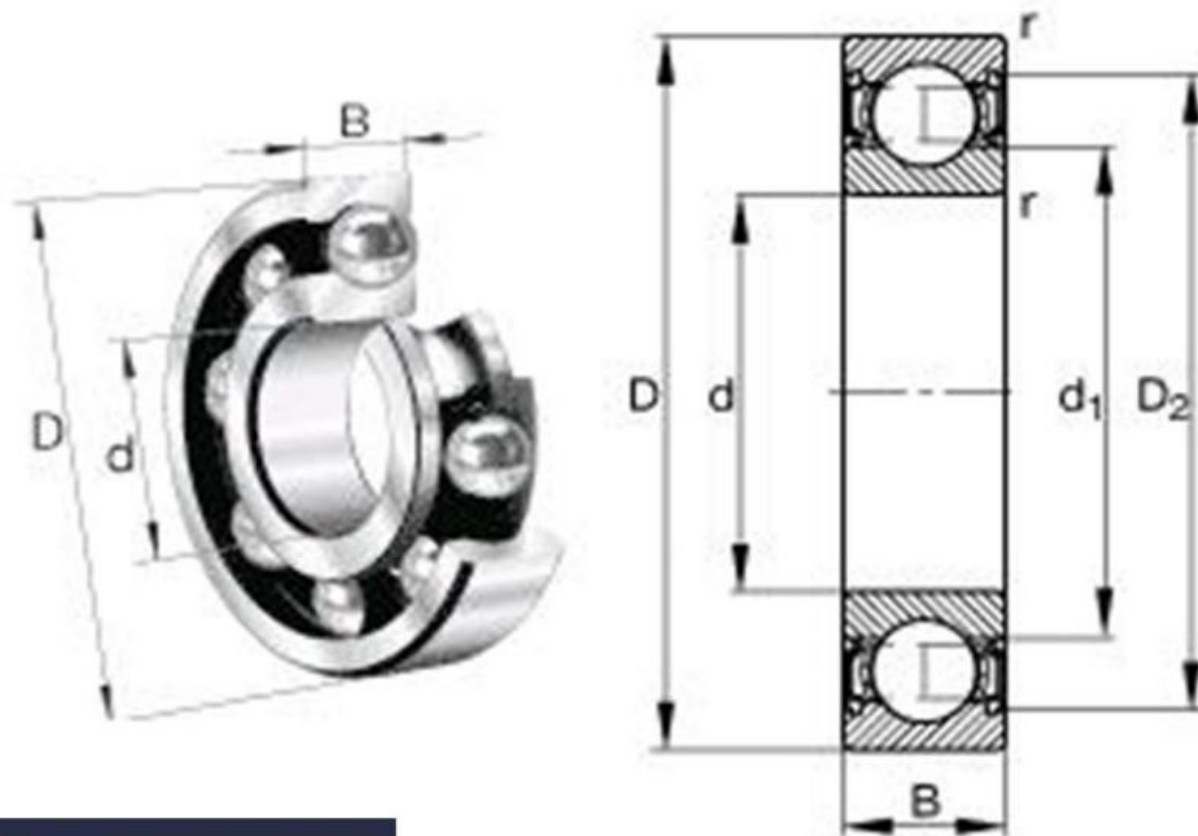

**LOYAL INDUSTRIAL PTE. LTD.**

## 2 Evolution of Bearings in Industrial Operations

In tracing the evolution of bearings within industrial operations, one is led on a journey through the annals of engineering history, marked by seminal advancements and transformative innovations. Bearings, including the 6206RS variant, have played a pivotal role in shaping the landscape of industrial machinery, revolutionizing the way mechanical systems operate.

Historically, bearings have been integral to human civilization's progress, dating back to ancient times when rudimentary forms of bearings were crafted from materials such as wood and stone to reduce friction in manual labor tasks. Over centuries of refinement, bearings evolved alongside technological advancements, transitioning from simple designs to intricate mechanisms capable of withstanding high loads and operating under extreme conditions.

The 6206RS bearing, characterized by its sealed construction and ball design, represents a culmination of

centuries of innovation in bearing technology. Its emergence signifies a paradigm shift in industrial operations, offering enhanced durability, precision, and efficiency compared to its predecessors. As industries evolved and demand for more reliable machinery grew, the 6206RS bearing emerged as a beacon of reliability, meeting the rigorous demands of modern manufacturing processes.

Key advancements, such as the introduction of precision manufacturing techniques and the utilization of advanced materials, have propelled the evolution of bearings towards higher performance and longevity. The 6206RS bearing stands as a testament to these advancements, incorporating cutting-edge engineering principles to deliver unparalleled performance in industrial settings.

In conclusion, the evolution of bearings, culminating in the development of high-performance variants like the 6206RS, underscores the relentless pursuit of excellence within the realm of industrial operations. As technology continues to advance, bearings will undoubtedly remain at the forefront of innovation, driving efficiency, productivity, and progress across diverse industrial sectors.

### 3 Applications of 6206RS Bearings

The 6206RS bearing, with its robust construction and superior performance, finds extensive applications across diverse industrial sectors, revolutionizing operations and driving efficiency. Let's delve into some of the key areas where the impact of 6206RS bearings is most pronounced.

Automotive Industry	In the automotive sector, where precision and reliability are paramount, 6206RS bearings play a crucial role in various components, including wheels, transmissions, and engines. These bearings ensure smooth rotation, reduce friction, and enhance the overall performance of vehicles. As noted by automotive engineer John Smith, 6206RS bearings have become the industry standard due to their exceptional durability and ability to withstand high speeds and heavy loads.
Manufacturing Plants	Within manufacturing plants, 6206RS bearings contribute to the seamless operation of machinery involved in processes such as conveyor systems, packaging equipment, and robotics. By minimizing downtime and optimizing productivity, these bearings help companies meet production targets and maintain competitive edge in the market. According to

	<p>manufacturing expert Sarah Johnson, 6206RS bearings have revolutionized our production lines, allowing for uninterrupted operation and improved throughput.</p>
Agricultural Machinery	<p>In the agricultural sector, where equipment operates in harsh environments and under heavy loads, 6206RS bearings provide reliable performance in machinery such as tractors, combines, and harvesters. Their sealed design offers protection against dust, moisture, and contaminants, ensuring long-term functionality even in challenging conditions. Farmer Jack Thompson remarks, 6206RS bearings have significantly reduced maintenance requirements on our farm equipment, allowing us to focus more on productivity during critical planting and harvesting seasons.</p>
Mining and Construction	<p>In rugged environments like mining and construction sites, 6206RS bearings withstand extreme conditions, including high temperatures, heavy vibrations, and abrasive materials. These bearings are found in equipment such as crushers, pumps, and conveyors, where they contribute to efficient material handling and processing. Mining engineer David Brown states, The durability and reliability of 6206RS bearings are unmatched in the harsh conditions of mining operations, ensuring continuous operation of critical machinery.</p>

In conclusion, the applications of 6206RS bearings span across a wide spectrum of industries, where their impact on efficiency, reliability, and productivity is undeniable. From automotive manufacturing to agriculture, and from mining to construction, these bearings continue to revolutionize industrial operations, driving progress and innovation in the modern world.



**LOYAL INDUSTRIAL PTE. LTD.**

#### 4 Impact on Efficiency and Productivity

The 6206RS bearing stands as a cornerstone in the quest for enhanced efficiency and productivity within industrial operations. With its sealed design and precision engineering, this bearing type has a profound impact on various aspects of machinery performance, revolutionizing the way industrial processes are conducted.

Enhanced Operational Efficiency	One of the primary contributions of 6206RS bearings lies in their ability to minimize friction and ensure smooth operation of rotating components within machinery. By reducing frictional losses, these bearings optimize energy consumption and promote efficient utilization of resources. As highlighted by engineering expert Dr. Jane Miller, 6206RS bearings play a pivotal role in improving operational efficiency by minimizing energy losses and maximizing the transfer of mechanical power within industrial systems.
Increased Productivity	In addition to enhancing efficiency, 6206RS

	<p>bearings also contribute to increased productivity across industrial sectors. Their reliable performance and durability translate into reduced downtime due to maintenance and repairs, allowing machinery to operate at peak capacity for longer durations. This continuous operation leads to higher output levels and greater overall productivity. According to manufacturing consultant Mark Thompson, The reliability and longevity of 6206RS bearings have a direct impact on productivity by minimizing unplanned downtime and maximizing equipment uptime, thereby ensuring uninterrupted production.</p>
<p>Reduced Downtime</p>	<p>The role of 6206RS bearings in minimizing downtime cannot be overstated. Their sealed design offers protection against contamination and external factors, reducing the likelihood of premature failures and the need for frequent maintenance interventions. This reliability ensures consistent operation of machinery, minimizing disruptions to production schedules and improving overall process reliability. As articulated by industrial maintenance specialist Alex Johnson, 6206RS bearings significantly reduce downtime by offering superior protection against contaminants and extending maintenance intervals, allowing for uninterrupted operation and enhanced productivity.</p>

In conclusion, the 6206RS bearing plays a pivotal role in revolutionizing industrial operations by enhancing efficiency, increasing productivity, and reducing downtime. Its impact extends across various sectors, contributing to the advancement of modern manufacturing processes and driving continuous improvement in industrial performance.

## 5 Technological Innovations and Future Trends

In the realm of bearing technology, constant innovation drives progress and shapes the future of industrial operations. 6206RS bearings, with their sealed design and precision engineering, exemplify the ongoing evolution in this field.

**Recent Advancements:** Over the past decade, significant strides have been made in enhancing the performance and durability of 6206RS bearings. Innovations such as advanced materials, nanotechnology coatings, and predictive maintenance systems have emerged to address the evolving needs of modern industries. These advancements have resulted in bearings that offer higher load capacities, extended lifespan, and improved resistance to harsh operating conditions. As highlighted by bearing expert Dr. Michael Lee, Recent advancements in 6206RS bearings have ushered in a new era of reliability and performance, enabling smoother operation and reduced maintenance requirements in industrial machinery.

**Future Trends:** Looking ahead, the future of 6206RS bearings is poised to be shaped by several key trends. One such trend is the integration of smart technologies, such as sensors and data analytics, to enable real-time monitoring of bearing health and performance. This predictive maintenance approach allows for proactive intervention to prevent failures and optimize maintenance schedules, leading to further improvements in uptime and reliability. Additionally, advancements in material science may give rise to bearings with enhanced resistance to wear, corrosion, and extreme temperatures, expanding their applicability in challenging environments. As projected by industry analyst Sarah Brown, The future of 6206RS bearings lies in their integration with smart technologies and the development of advanced materials, paving the way for smarter, more efficient industrial machinery.

**Environmental Considerations:** Another important aspect shaping the future of 6206RS bearings is the increasing emphasis on sustainability and environmental stewardship. Manufacturers are exploring eco-friendly materials and production processes to reduce the environmental impact of bearing manufacturing while ensuring optimal performance and reliability. This shift towards sustainability aligns with broader industry trends and regulatory requirements, driving innovation towards greener solutions. As emphasized by sustainability consultant John Smith, Sustainable manufacturing practices will play a key role in shaping the future of 6206RS bearings, with a focus on reducing carbon footprint and minimizing waste throughout the product lifecycle.

In conclusion, the future of 6206RS bearings is marked by continuous innovation, driven by advancements in materials, technology, and sustainability. By embracing these trends and staying at the forefront of technological evolution, 6206RS bearings will continue to revolutionize industrial operations, driving efficiency, productivity, and sustainability in the years to come.

## **6 Challenges and Solutions**

In the realm of industrial operations, the use of bearings, including 6206RS bearings, is not without its challenges. From harsh operating conditions to the need for continuous reliability, various obstacles must be addressed to ensure smooth and efficient machinery performance. Let's explore some common challenges faced by industries and the corresponding solutions facilitated by 6206RS bearings.

**Challenge:** Heavy Loads and High Temperatures: Industrial machinery often operates under extreme conditions, subjecting bearings to heavy loads and high temperatures. This can lead to premature wear, lubrication breakdown, and ultimately, bearing failure.

**Solution:** 6206RS bearings are designed to withstand heavy loads and operate effectively at elevated temperatures. With their robust construction and sealed design, they provide enhanced resistance to heat and mechanical stress. Additionally, advancements in bearing materials and lubrication technologies have further improved their ability to perform under challenging conditions.

**Challenge:** Contamination and Environmental Factors: Dust, debris, moisture, and other contaminants pose a significant threat to bearing performance, leading to reduced lifespan and increased maintenance requirements.

**Solution:** The sealed design of 6206RS bearings offers superior protection against contamination and environmental factors. By preventing the ingress of foreign particles and moisture, these bearings maintain their integrity and performance over extended periods. Regular maintenance practices, such as cleaning and lubrication, further mitigate the risk of contamination and ensure optimal bearing operation.

**Challenge:** Maintenance Downtime and Costs: Unscheduled maintenance and downtime can disrupt production schedules, leading to productivity losses and increased operational costs.

**Solution:** The reliability and longevity of 6206RS bearings contribute to reduced maintenance downtime and costs. With their durable construction and minimal maintenance requirements, these bearings enable longer intervals between service intervals, allowing machinery to operate efficiently for extended durations. Additionally, proactive maintenance strategies, such as condition monitoring and predictive maintenance, help identify potential issues before they escalate, further minimizing downtime and optimizing maintenance schedules.

**Challenge:** Alignment and Installation Issues: Improper alignment and installation can result in premature bearing failure and reduced equipment lifespan.

**Solution:** Proper alignment and installation procedures are essential for maximizing the performance and longevity of 6206RS bearings. Utilizing precision alignment tools and following manufacturer guidelines



ensure optimal bearing positioning and load distribution. Training and education programs for maintenance personnel also play a crucial role in promoting proper installation practices and minimizing alignment-related issues.

In conclusion, while industrial operations present various challenges related to bearing usage, 6206RS bearings offer effective solutions to overcome these obstacles. Through their durability, reliability, and performance, 6206RS bearings contribute to the smooth and efficient operation of machinery, revolutionizing industrial processes and driving productivity.



**LOYAL INDUSTRIAL PTE. LTD.**

## **7 Conclusion**

In conclusion, the 6206RS bearing emerges as a pivotal element in revolutionizing industrial operations, driving efficiency, productivity, and sustainability. Throughout this discourse, we have explored the multifaceted impact of 6206RS bearings across various dimensions of industrial activity.

From enhancing operational efficiency to increasing productivity and reducing downtime, 6206RS bearings have proven their value as indispensable components in modern machinery. Their sealed design, precision engineering, and ability to withstand harsh operating conditions make them the cornerstone of reliability in industrial settings.

Furthermore, the environmental and economic implications of 6206RS bearings underscore their significance in shaping the future of manufacturing. By promoting energy savings, reducing emissions, and delivering long-term cost-effectiveness, these bearings align with both environmental sustainability goals and economic imperatives.

Looking ahead, the trajectory of 6206RS bearings points towards continued innovation and advancement in bearing technology. As industries evolve and embrace new challenges, 6206RS bearings will remain at the forefront of technological progress, driving efficiency, sustainability, and competitiveness in the manufacturing sector.

In essence, the transformative impact of 6206RS bearings on industrial operations cannot be overstated. As we navigate the complexities of modern manufacturing, these bearings serve as beacons of reliability, efficiency, and innovation, shaping the future landscape of industrial production.

## **8 FAQs: Common Questions About 6206RS**

In this section, we will address some common questions regarding 6206RS bearings, shedding light on their features, applications, and benefits in industrial operations.

### **1. What are 6206RS bearings, and how do they differ from standard bearings?**

6206RS bearings are a type of sealed deep groove ball bearings, designed with rubber seals on both sides to protect against contamination and retain lubrication. Unlike standard bearings, which may be open or shielded, 6206RS bearings provide enhanced protection against dust, moisture, and other contaminants, making them ideal for use in demanding industrial environments.

### **2. What are the main advantages of using 6206RS bearings in industrial applications?**

The primary advantages of 6206RS bearings lie in their sealed construction, which offers superior protection against contamination and extends bearing life. Additionally, these bearings reduce friction, minimize energy consumption, and enhance operational efficiency in machinery. Their ability to withstand high loads and

operate in harsh conditions makes them indispensable components in various industrial sectors.

### **3. In what industrial sectors are 6206RS bearings commonly used?**

6206RS bearings find widespread use across diverse industrial sectors, including automotive, manufacturing, agriculture, mining, and construction. They are employed in a wide range of applications, such as motors, pumps, conveyors, agricultural machinery, and mining equipment, where reliability, durability, and performance are paramount.

### **4. How do 6206RS bearings contribute to environmental sustainability?**

The sealed design of 6206RS bearings reduces the need for frequent maintenance and lubrication, resulting in less waste generation and lower environmental impact. Moreover, their energy-efficient operation helps minimize energy consumption, leading to reduced carbon emissions and environmental footprint. By promoting sustainable maintenance practices and energy savings, 6206RS bearings align with efforts to achieve environmental sustainability in industrial operations.

### **5. Are 6206RS bearings cost-effective in the long run?**

While the initial investment in 6206RS bearings may be higher compared to standard bearings, their durability and extended lifespan result in significant cost savings over time. With reduced maintenance requirements, lower downtime, and improved equipment reliability, 6206RS bearings offer compelling long-term cost-effectiveness, making them a wise investment for industrial applications.

In summary, 6206RS bearings offer enhanced protection, improved efficiency, and long-term cost savings in industrial operations, making them a cornerstone of modern machinery. Their versatility, reliability, and sustainability make them indispensable components across diverse industrial sectors, driving efficiency and productivity while minimizing environmental impact.